



AVID

AIR SPEED MULTI STREAM

Multi-format HD and SD ingest and playout

THE WORKFLOW SERVER

The AirSpeed® Multi Stream server extends and accelerates the Avid digital production environment with directly-connected ingest and playout capability. Designed for broadcast and production applications with regular feed or live acquisition and playback needs, AirSpeed Multi Stream directly records into an Avid Unity™ shared media network, allowing incoming material to be used immediately by all contributors. Native support for digital HD and SD acquisition formats smooths production workflow and saves time at each end of your nonlinear workflow. AirSpeed Multi Stream has a big impact on productivity with up to 4 simultaneous XDCAM HD channel capacity in the HD/SD model, but its small 1.5RU form factor and low per-channel power and cooling demand has a modest impact on your facility. And when it comes to facility fit, AirSpeed Multi Stream interoperates and integrates easily with your existing systems, applications, and processes—including third-party automation systems.

END-TO-END PRODUCTION WORKFLOW IN YOUR FORMAT

Native XDCAM HD and XDCAM EX format support eliminates transcoding steps and work-arounds for faster and simpler start-to-finish workflow. AirSpeed Multi Stream is available in HD+SD and upgradeable SD models, so you can choose the capability that fits your current and future plans and avoid paying for what you don't need. XDCAM users will appreciate that AirSpeed Multi Stream uses Sony hardware codecs for a full-spec XDCAM HD and XDCAM EX implementation that helps to maximize their XDCAM investment.

FASTER PRODUCTION

The AirSpeed® Multi Stream server works with Avid® NewsCutter®, iNEWS® Instinct®, Media Composer® or Symphony™ editors to virtually eliminate the time between acquisition and editing. FrameChase™ editing means that workgroup-connected editing stations can play and edit material seconds after the transfer begins, speeding up both ends of the process in time-critical news, talk show, and sports production. Direct connection and full interoperability with the Avid Unity media network and Avid Interplay® production management system provides all contributors with immediate access to material and automatically generated headframes for each clip. With one command, finished segments are sent to AirSpeed Multi Stream and stored locally for later playback.

AUTOMATED CAPTURE AND PLAYBACK

The AirSpeed Multi Stream server interfaces easily with automation systems through industry standard VDCP and Sony BWW protocols, and supports external timecode. Full integration and testing with the Avid CaptureManager™ ingest control and iNEWS Command playback control applications ensures cost-effective and reliable play to air under automated, assisted, or manual control.

SIZED RIGHT

With a small 1.5RU form factor and support for up to four record, playback, or mixed 50Mb HD streams, the AirSpeed Multi Stream server is the most efficient way to address your video acquisition and playback requirements. Channels can be remotely reassigned for ingest or playback for added flexibility that saves time and expense. The compact, efficient design of the AirSpeed Multi Stream server saves on your power and cooling requirements too.

UPGRADEABLE CODECS

The AirSpeed Multi Stream server was designed with the future in mind. The SD model is field-upgradeable to simplify SD to HD transition, and both AirSpeed Multi Stream models are designed to enable support for other formats and resolutions, allowing facilities and broadcasters to adopt new acquisition formats without total hardware replacement.

RELIABLE PLAY TO AIR

Safe playout transmission is ensured by caching material from shared storage onto the AirSpeed Multi Stream system's internal storage. Grouping up to four systems in a Studio configuration provides redundancy and flexibility for even greater playout confidence, and the option for failover channels in conjunction with the iNEWS Command playback control application.

EXTENDED ACCESS

A straightforward user interface provides a single point to remotely set-up, preview, browse, and control all AirSpeed Multi Stream servers from one or more desktops. Clips are easily identified with reference frames and all media residing on local AirSpeed Multi Stream or Avid Unity storage is as accessible to the feed room operations as it is to the connected editing clients. From the preview monitor, clips can be played with audio on a VGA monitor, and users can mark In and Out points, create sub clips and set head frames.

QUALITY, PERFORMANCE AND VALUE – Input to Output.

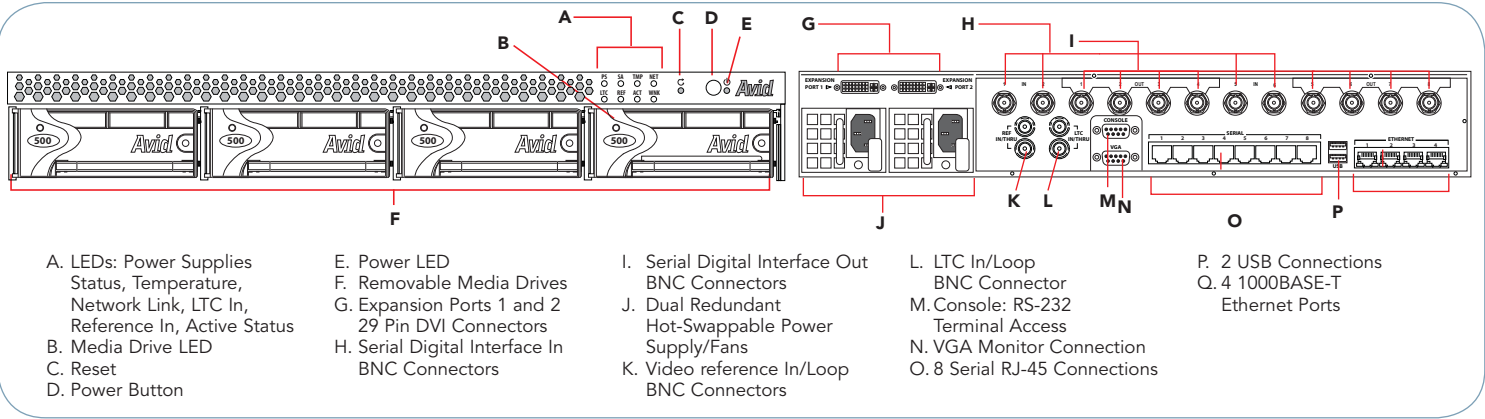

PRODUCT HIGHLIGHTS

Compact size and a complete range of video and audio I/O, control, and sync connections facilitate easy integration with a facility's existing signal and control infrastructure.

SPECIFICATIONS

Physical

Physical Dimensions

- inches: 19.00 (w) x 2.6 (h) x 28.5 (d)
- cm: 48.3 (w) x 6.6 (h) x 72.4 (d)
- Rack Units: 1.5

Weight

- Pounds: 48
- Kilograms: 21.8

Power

- 100 to 240 VAC, 50/60 Hz auto ranging, 780W maximum; 415 watts typical

Environmental

- 5°C to 40°C, 85% RH non-condensing
- 1417 BTU/hr. typical

Audio

Channels

- SD SDI 8 channels (4 streams) embedded audio per video stream
- HD SDI 16 channels (8 streams) embedded audio per video stream

Sampling

- 48 KHz, 16, or 24 bit precision

AC-3 and Dolby E

- Fully compatible with professional and consumer encoding

Video

HD and SD Models

- 525/625 selectable

AirSpeed Multi Stream HD

- HD: 1080i HDV 25Mbps, 720p and 1080i XDCAM EX 35 Mbps, 1080i XDCAM HD 17.5, 35 and 50 Mbps, 720p XDCAM HD 50 Mbps

- SD: DVCPRO25, DVCPRO50, IMX30 and IMX50
- Mixed HD/SD operation

AirSpeed Multi Stream SD

- DVCPRO25, DVCPRO50, IMX30 and IMX50

Video Input

- (For SD Model) 2 SDI (SMPTE 259M)
- (For HD Model) 4 SDI (SMPTE 259M, SMPTE 292M, SMPTE 295M, SMPTE 296M)

Video Output

- (For SD Model) 6 SDI (SMPTE 259M)
- (For HD Model) 4 SDI (SMPTE 259M, SMPTE 292M, SMPTE 295M, SMPTE 296M) – Maximum of 4 simultaneously supported

Video Compression

- DV25 (4:1:1 and 4:2:0), DV 50 (4:2:2), IMX 30 and 50, HDV 25Mbps, XDCAM EX 35Mbps, XDCAM HD 17.5, 35 and 50 Mbps

Video Monitoring

- 1 VGA port

Control and Synchronization

External Control

- VDCP
- Sony BVW

Manual Control

- Record, play, trimming, and configuration through graphical user interface.

Timecode

- LTC SMPTE 12M Single Ended I/O
- VITC SMPTE 266 Compatible with Input and Output Line Selections (VITC preservation supported with IMX30 and IMX 50 only)

Reference

- Analog black burst/tri-level reference, looping input

Output Timing

- 5 lines advance to 3 lines delay in the following pixel steps based on timecode: 1/2 for SMPTE 259M; 1 for SMPTE 292M; 1 for SMPTE 295M; 1 for SMPTE 296M

Internal Time

- Derived from LTC single ended SMPTE - 12M reference input

Closed Caption

- All Closed Caption lines for IMX30 and IMX 50 are preserved

Data

Keyboard/Mouse Port

- 2 USB 2.0 connectors for USB-compatible keyboard and mouse

Ethernet Port

- 4 RJ-45 connectors, 10BASE-T, 100BASE-T, or 1000BASE-T, auto sensing (1000BASE-T required for Avid Unity network interconnection)

Rear Panel Connections

Serial Remotes 1-8:

- RJ45 connector, RS-422

LTC Out

- 4 BNC connectors on Expansion port cable connected to 29-pin female DVI connector

LTC In

- 1 BNC connector; Loop through: 1 BNC connector

SDI In

- SD Model (2) BNC; HD model (4) BNC

SDI Out

- SD Model (6) BNC; HD Model (4) BNC

Reference In

- BNC connector

Reference Loop through

- In: BNC connector; Loop through: BNC connector

Avid Total Services

Providing faster return on your investment by getting your systems and personnel up and running quickly, maximizing workflow efficiency, and meeting your production schedules. To learn more about Avid Total Services, please visit: www.avid.com/services.

Corporate Headquarters
800 949 AVID (2843)

Asian Headquarters
+ 65 6476 7666

European Headquarters
+ 44 1753 655999

Avid®